

INLT220Q - ILaS[®] Transceiver

FEATURES

- ILaS[®] cable interfaces with failover pass-through (Initiator & Extension Port)
- ISELED[®] client side port
- 3 GPIO's for control of external devices for Sensor and Actuator Integration
- Differential, serial, bi-directional, Daisy-Chain Communication over cable interfaces and client side port
- Up to 4079 devices in one segmented Daisy-Chain network
- Individually, broadcast or multicast addressable ISELED[®] LEDs
- Built-in temperature sensor and on-chip oscillator
- DCDC buck controller for use with single 12V supply
- Option to disable DCDC buck controller
- Low power mode and wake-up signaling
- eFuse OTP memory
- Built-in diagnostic functions
- Optional mode for protocol sniffing
- 40V resistant cable PHY with 8KV ESD protection (HBM)
- -40°C to +105°C temperature range
- AEC-Q100 automotive qualification
- 5mm x 5mm package

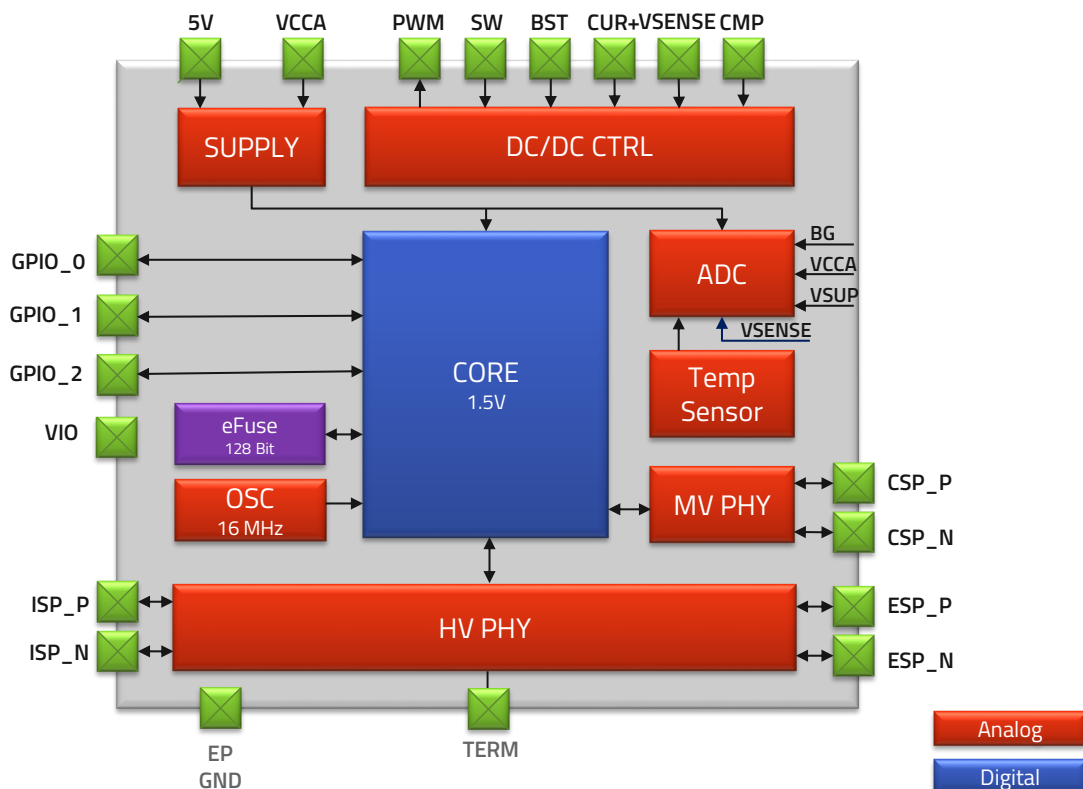

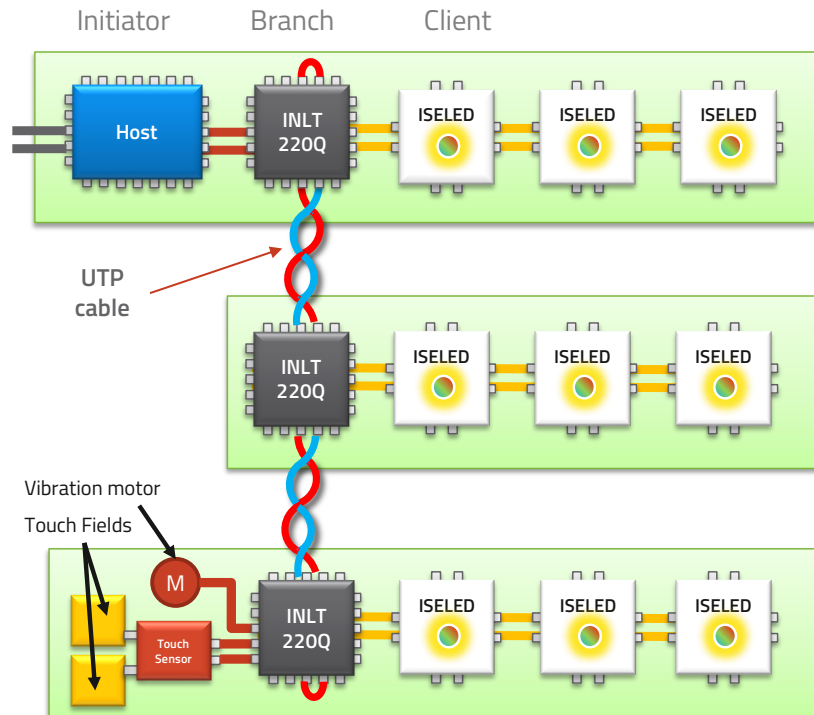

APPLICATIONS

- Light and Sensor networks in vehicles
- Dynamic Interior Ambient Lighting
- Functional Lighting
- Smart Dashboard Control and Lighting
- Foot room Lighting, Door / Roof & Dome Lighting
- Automotive networking Hubs (Ethernet, LIN, etc.)

Part Number	Package	Packing	MOQ
INLT220Q-T	WETQFN-20	Tray	490
INLT220Q-R5	WETQFN-20	Reel	5000



Integrated Smart Embedded LED

ISELED® Light and Sensor Network

ISELED® and LaS® are registered trademarks of Inova Semiconductors GmbH



CONNECTIVITY FOR AUTOMOTIVE LIGHT & VISION